

# Shower Sump Pump Systems

Attwood's shower sump systems deliver the performance you've been asking for. Choose from standard box or large box sizes. Offering fast water flow into and out of sump. The lid snaps in to allow quick installation (and removal for cleaning) and includes a gasket to seal the sump box against overflow. The sump box even includes an air vent to prevent air locks. Meets or exceeds all applicable standards of the ABYC and USCG.

\* **⚠ WARNING** Cancer and Reproductive Harm

— [www.P65Warnings.ca.gov](http://www.P65Warnings.ca.gov) (see page 240)

Multiple Inlets Can Be Hooked Up to More Than One Drain – Using Different Hose Sizes

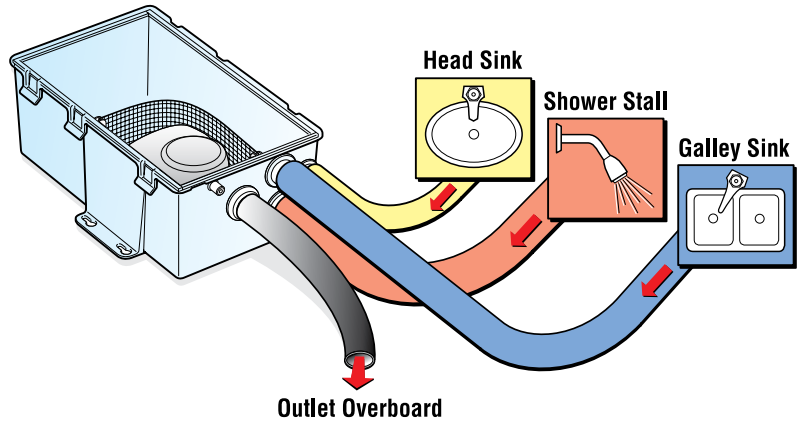

## Specifications

Model	Rated Voltage	Fuse Size	Outlet Hose Size
500 GPH	12-volt	3-amps	3/4" I.D.
750 GPH	12-volt	5-amps	3/4" I.D.
750 GPH	24-volt	2-amps	3/4" I.D.

## Output Ratings

Model	Amp Draw	GPH Output @ Design Voltage 13.6 VDC			GPH Output @ Nominal Voltage 12.0 VDC		
		0 ft.	3.3 ft.	6.7 ft.	0 ft.	3.3 ft.	6.7 ft.
500 GPH	1.4	420	360	215	385	290	130
750 GPH	2.5	650	500	385	570	420	290

Performance for 24-Volt version is the same (Uses 2 Amp Fuses)

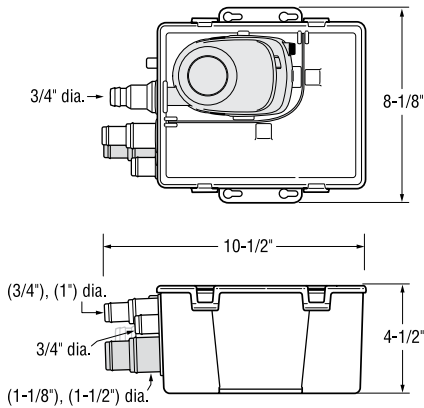
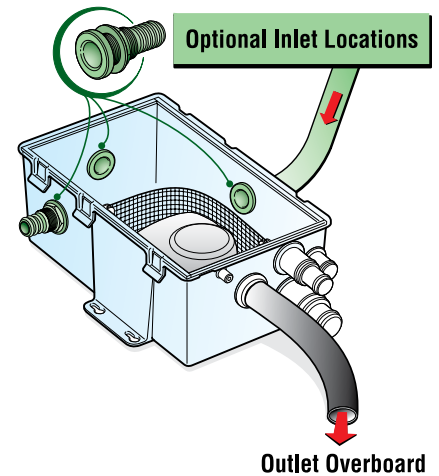

Standard Box

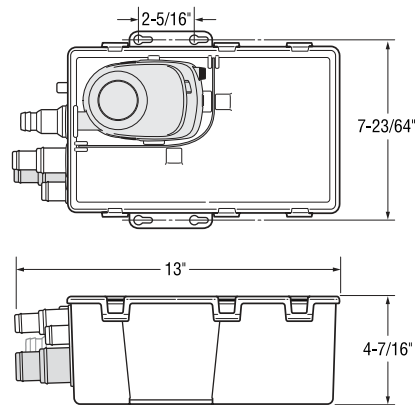

Large Box



4141



4143

Model No.	Rated Voltage	Wire/ Connector	Box Size	Bulk Packaging	Prop 65	Aftermarket Packaging	Prop 65
500 GPH	12-volt	22" wire	Standard	4141-1	*	4141-4	*
750 GPH	12-volt	22" wire	Standard	4142-1	*	—	—
750 GPH	12-volt	22" wire	Large	4143-1	*	4143-4	*
750 GPH	24-volt	22" wire	Large	4144-1	*	—	—
750 GPH	24-volt	22" wire	Standard	4145-1	*	—	—
Lid	—	—	Standard	001001668	*	—	—
Lid	—	—	Large	001001667	*	—	—

