

THANK YOU

Thank you for choosing Humminbird®, the #1 name in marine electronics. Humminbird has built its reputation by designing and manufacturing top-quality, thoroughly reliable marine equipment. Genuine Humminbird accessories offer the opportunity to upgrade and expand the capabilities of your Humminbird product.

 **NOTE:** Your transducer may not look exactly like the transducer shown in the illustrations, but it will mount in exactly the same way.

Your Humminbird is designed for trouble-free use in even the harshest marine environment. In the unlikely event that your Humminbird does require repairs, we offer an exclusive Service Policy - free of charge during the first year after purchase, and available at a reasonable rate after the one-year period. For complete details, see the Warranty section included in this manual.

INSTALLATION OVERVIEW

Following are instructions for the installation of this accessory. Before you start installation, we encourage you to read these instructions carefully in order to get the full benefit from your Humminbird accessory.

Customer Service: If you find that any items are missing from your installation kit, visit our Web site at humminbird.com or call Customer Service at 1-800-633-1468.

 **NOTE:** This type of transducer installation is not recommended for trailerable boats.

 **NOTE:** This transducer requires drilling a hole in the hull of the boat; therefore, installation should be performed by a qualified marine technician.

Supplies: In addition to the hardware supplied with your transducer, you will need a drill, a small drill bit for a pilot hole, a 1 1/8" hole saw, a level, and marine-grade silicone sealant.

INSTALLATION

Perform the procedures in the following sections to install the transducer on your boat.

1 | Test the Transducer Prior to Installation

Prior to installation, test the transducer to make sure that no damage occurred during shipping.

1. Connect the transducer cable connector to the control head or black box sonar (depending on your system configuration).

 **NOTE:** If using a black box sonar, confirm it is connected to the control head.

2. Power on the control head. Select a sonar view to display on-screen.

 **NOTE:** See your control head operations manual for more information.

3. Hold the transducer in the water over the side of the boat to confirm proper operation. If the transducer is working properly, you should be able to see the bottom on the control head display. The bottom image should be relatively strong and there should be detailed structure on the display.
4. After confirming proper operation, unplug the transducer cable connector from the control head or black box sonar.

Thru-Hull Installation

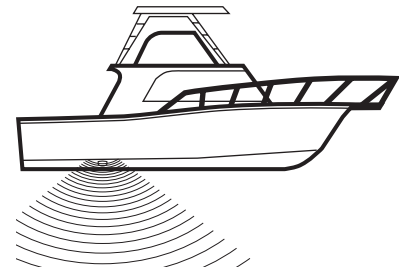

PLASTIC THRU-HULL DOWN IMAGING® TRANSDUCER

532142-1_C

2 | Locate the Transducer Mounting Position

Consider the following to find the best location to install the transducer.

Outside the boat: The best location for the transducer will be aft midship, as close to the centerline of the boat as possible.

- The transducer should be mounted forward of the propellers on inboard boats, and separated adequately from other transducers, strakes, rivet lines, or other protrusions.
- Make sure that there is nothing in front, behind, or to the side of the transducer that is closer than 12".

⚠ WARNING! Do **NOT** install the transducer in line with the engine intake.

Inside the boat: There must be room to access the mounting location for installation and cable routing.

Deadrise: Another consideration is the angle of deadrise.

- The transducer, when mounted, should be parallel with the water line. This positioning allows the beam elements to point straight down. If the selected mounting location has a hull deadrise of 2 degrees or greater, the included leveling block should be used to level the transducer housing and direct the sonar signal straight down.
- If you need to use the leveling block, make sure that the inside surface of the hull is smooth enough to seat the leveling block securely.

Installation scenarios for consideration:

- **Flat Hull:** Locate a flat area on the bottom of the hull, forward of where the propeller shaft comes out of the hull. Make sure there is nothing lower than this location to the right or left.

✍ NOTE: Rough seas, high speed, and air bubbles can affect the reading of the Down Imaging beam.

✍ NOTE: If the included transducer will not work for your application, you may exchange it, **NEW and UNASSEMBLED**, with mounting hardware included, for a transducer appropriate for your application - often at very little or no charge depending on the transducer. See the FAQ [Frequently Asked Questions] section of our Web site at humminbird.com or call Customer Service at **1-800-633-1468**.

3 | Drill the Hole and Install the Leveling Block

Follow the instructions below for the installation type that matches your hull and deadrise.

⚠ CAUTION! Use only the leveling block included with this transducer. Do **NOT** use a wooden leveling block, as any swelling of the wood might cause the plastic on the transducer to shatter.

✍ NOTE: Replacement leveling blocks are available from Humminbird. For assistance, contact Humminbird Customer Service at humminbird.com or call **1-800-633-1468**.

Standard Installation [Flat Hull, Deadrise less than 2°]: For an installation that needs to minimize the impact of a small obstruction, but where the deadrise is less than 1 - 2 degrees, use the included leveling block [uncut], and mount it outside the hull.

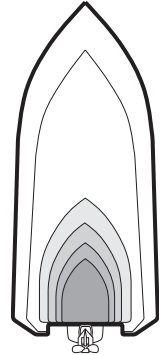
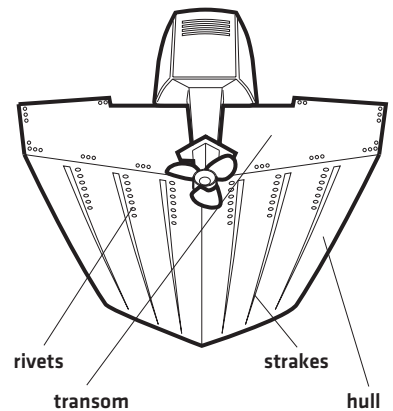
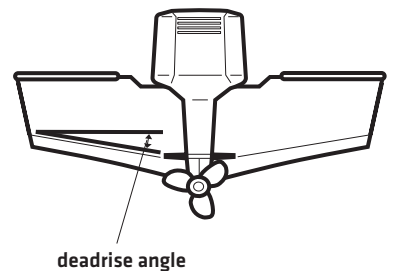
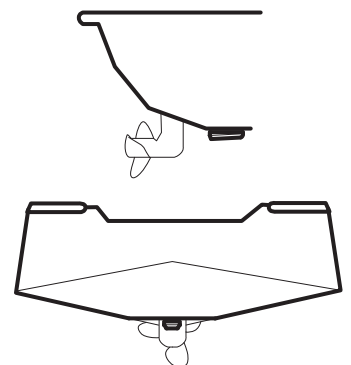
Preferred Mounting Location

Areas of Possible Turbulence

Deadrise

Flat Hull, One Transducer

PLASTIC THRU-HULL DOWN IMAGING® TRANSDUCER

532142-1_C

1. From the outside of the hull, drill a small pilot hole [smaller than the centering bit of your drill bit or hole saw], at the mounting location you selected in section 2.

⚠ CAUTION! Before you drill, make sure you are drilling the hole perpendicular to the hull.

2. Use the pilot hole [from the outside of the hull] to drill a 1 1/8" hole that is sized to fit the threaded stem of the transducer. Drill the hole perpendicular to the hull.
3. Thoroughly clean and deburr the drilled hole and clean the outside of the hull.
4. The leveling block will be installed [uncut] on the outside of the hull. Proceed to **Attach the Transducer**.

Alternate Installation (Deadrise more than 2°): For an installation where the deadrise is more than 2 degrees, use the included leveling block, cut at the appropriate angle, to compensate for the deadrise.

1. From the outside of the hull, drill a small pilot hole [smaller than the centering bit of your drill bit or hole saw], at the mounting location you selected in section 2.

⚠ CAUTION! Before you drill, make sure you are drilling the hole perpendicular to the waterline.

2. Use the pilot hole [from the outside of the hull] to drill a 1 1/8" hole that is sized to fit the threaded stem of the transducer. Drill the hole perpendicular to the waterline.
3. Thoroughly clean and deburr the drilled hole and clean the outside of the hull.
4. If the hull angle is greater than 2 degrees, cut the included leveling block and use both pieces to level the transducer. The block should be cut to match the angle of the deadrise of the hull.
 - Cut the leveling block into two equal pieces: one which mounts outside the hull and is shaped to match the profile of the transducer, and one which mounts inside the hull and provides a level surface for the fasteners.
 - The thinnest wall of the outside leveling block must be at least 1/8".
 - The leveling block included with your transducer can accommodate a maximum deadrise angle of 25 degrees.
5. The leveling block will be installed [cut] on the inside and outside of the hull. Proceed to **Attach the Transducer**.

4 | Attach the Transducer

1. Feed the transducer cable through the drilled hole, then temporarily install the transducer to check the fit.
2. Apply a generous amount of marine-grade silicone sealant or slow-curing epoxy inside the drilled hole and along the mating surfaces of the transducer housing and leveling block.
3. See the illustrations that correspond to your installation type and transducer orientation.
 - Insert the transducer into the drilled hole from outside the boat with the leveling block[s] installed according to your installation type, then install the nut onto the threaded stem from inside the boat. Hand tighten the nut **ONLY** until the assembly is firmly seated, then tighten **NO MORE** than 1/8 of a turn extra.

⚠ CAUTION! To avoid damage, do not overtighten the nut.

- Make sure that the rounded end of the transducer is pointing forward [toward the bow of the boat]. The square end should be pointing towards the stern of the boat.

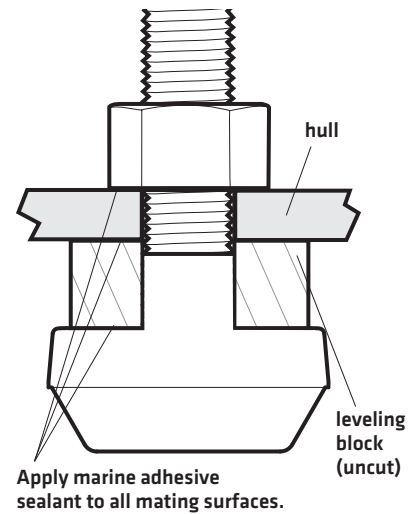
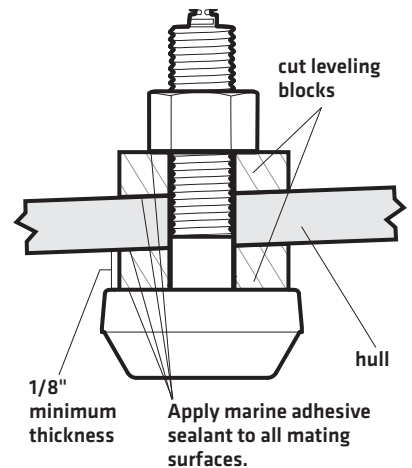
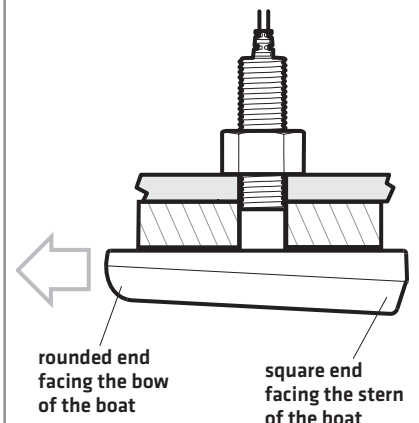
Standard Installation (Flat Hull)

Alternate Installation (Deadrise greater than 2°)

Correct Orientation of Transducer

PLASTIC THRU-HULL DOWN IMAGING® TRANSDUCER

532142-1_C

 **NOTE:** This type of transducer is directional in nature and must be aligned with the front of the boat [the direction of travel] and parallel to the center line. Failure to align the transducer properly will result in incorrect bottom readings and incorrect fish locations. [See the illustrations for orientation].

4. Remove the excess adhesive sealant from the outside of the hull to ensure smooth water flow over the transducer.

5 | Route the Cable

The transducer cable must be routed to the point where the control head is mounted.

 **NOTE:** Your boat may have a pre-existing wiring channel or conduit that you can use for the transducer cable.

1. Route and secure the cable, avoiding areas where it may be damaged or interfere with normal boating operations.

 **CAUTION!** Do not cut or shorten the transducer cable, and try not to damage the cable insulation. Route the cable as far as possible from any VHF radio antenna cables or tachometer cables to reduce the possibility of interference. If the cable is too short, extension cables are available to extend the transducer cable up to a total of 50'. For assistance, contact Customer Service at humminbird.com or call **1-800-633-1468** for more information.

 **CAUTION!** Do NOT mount the cables where the connectors could be submerged in water or flooded. If cables are installed in a splash-prone area, it may be helpful to apply dielectric grease to the inside of the connectors to prevent corrosion. Dielectric grease can be purchased separately from a general hardware or automotive store.

6 | Connect the Cable

1. Connect the transducer cable connector to the proper port on the control head or black box sonar [depending on your system configuration]. The ports are labeled and the cable connectors are keyed to prevent incorrect installation, so be careful not to force the connector into the wrong port. See your control head installation guide for details.

 **NOTE:** If the connector on the cable is round, it has a screw nut [see the illustration **Transducer Connectors**]. Hand tighten the screw nut to secure the cable connection. **Hand tighten only!**

 **NOTE:** If using a black box sonar, confirm it is connected to the control head.

Your control head is now ready for operation.

Transducer Connectors

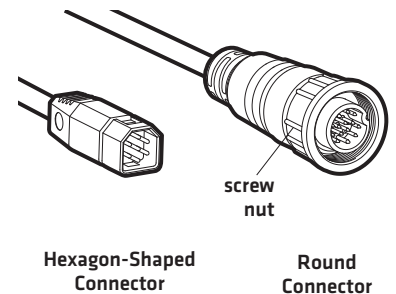

MAINTENANCE

If your boat remains in the water for long periods of time, algae and other marine growth can reduce the effectiveness of the transducer. Periodically clean the face of the transducer with a mild, marine-safe and plastic-safe soap or solution.

If your boat remains out of the water for a long period of time, it may take some time to wet the transducer after it is returned to the water. Small air bubbles can cling to the surface of the transducer and interfere with proper operation. These bubbles will dissipate with time, or you may wipe the face of the transducer with your fingers after the transducer is in the water.

1-YEAR LIMITED WARRANTY

We warrant the original retail purchaser that products made by Humminbird have been manufactured free from defects in materials and workmanship. This warranty is effective for one year from the date of original retail purchase. Humminbird products found to be defective and covered by this warranty will be repaired or replaced free of charge at Humminbird's option and returned to the customer freight prepaid. Humminbird's sole responsibility under this warranty is limited to the repair or replacement of a product that has been deemed defective by Humminbird. Humminbird is not responsible for charges connected with the removal of such product or reinstallation of replaced or repaired parts.

This warranty does not apply to a product that has been:

- Improperly installed;
- Used in an installation other than that recommended in the product installation and operation instructions;
- Damaged or has failed because of an accident or abnormal operation;
- Repaired or modified by entities other than Humminbird.

Please retain your original receipt as a proof of the purchase date. This will be required for in-warranty service.

THIS WARRANTY IS EXPRESSLY IN LIEU OF ANY OTHER WARRANTIES, OBLIGATIONS OR LIABILITIES ON THE PART OF HUMMINBIRD AND WILL BE THE CUSTOMER'S EXCLUSIVE REMEDY, EXCEPT FOR ANY APPLICABLE IMPLIED WARRANTIES UNDER STATE LAW WHICH ARE HEREBY LIMITED IN DURATION TO ONE YEAR FROM THE DATE OF ORIGINAL PURCHASE. IN NO EVENT WILL HUMMINBIRD BE LIABLE FOR ANY INCIDENTAL OR CONSEQUENTIAL DAMAGES FOR BREACH OF ANY EXPRESS OR IMPLIED WARRANTY RELATING TO THE PRODUCTS.

Some states do not allow limitations on an implied warranty, or the exclusion of incidental or consequential damages, so the above exclusions may not apply to you. You may also have other rights, which vary from state to state.

HUMMINBIRD SERVICE POLICY

Even though you'll probably never need to take advantage of our incredible service policy, it's good to know that we back our products this confidently. We do it because you deserve the best. We will make every effort to repair your unit within three business days from the receipt of your unit at our factory. This does not include shipping time to and from our factory. Units received on Friday are typically shipped by the following Wednesday, units received Monday are typically shipped by Thursday, etc.

All repair work is performed by factory-trained technicians to meet exacting factory specifications. Factory-serviced units go through the same rigorous testing and quality control inspections as new production units.

After the original warranty period, a standard flat rate service charge will be assessed for each repair (physical damage and missing parts are not included). Any repairs made after the original warranty will be warranted for an additional 90 days after service has been performed by our factory technicians. You can contact Customer Service or visit our Web site to verify the flat rate repair fee for your product (visit the Product Support section):

<http://www.humminbird.com>

We reserve the right to deem any product unserviceable when replacement parts are no longer available or impossible to obtain. This Service Policy is valid in the United States only. This applies only to Humminbird products returned to our factory in Eufaula, Alabama. This Service Policy is subject to change without notice.

DOMESTIC (USA) CUSTOMERS:

PLEASE DO NOT RETURN THIS PRODUCT TO STORE FOR SERVICE

For all technical issues please call **1-800-633-1468**

or visit **humminbird.com**, click **SUPPORT**.

Please reference product serial number and model number when contacting Humminbird.

PLASTIC THRU-HULL DOWN IMAGING® TRANSDUCER

532142-1_C

RETURNING YOUR UNIT FOR SERVICE

Before sending your unit in for repair, please contact the factory, either by phone or by email, to obtain a Repair Authorization Number for your unit.

 **NOTE:** Please do not return your Humminbird to the store for service.

Please have your product model name and serial number available before calling the factory. If you contact the factory by e-mail, please include your product model name and serial number in the e-mail, and use Request for Repair Authorization Number for your e-mail subject header. You should include your Repair Authorization Number in all subsequent communications about your unit.

For IN-WARRANTY service, complete the following steps:

- Obtain a Repair Authorization Number from Humminbird Customer Service.
- Tag product with your name, street address, phone number and your assigned Repair Authorization Number.
- Include a brief written description of the problem.
- Include a copy of your receipt [to show proof and date of purchase].
- Return product freight prepaid to Humminbird, using an insured carrier with delivery confirmation.

For OUT-OF-WARRANTY service, complete the following steps:

- Obtain a Repair Authorization Number from Humminbird Customer Service.
- Include payment in the form of credit card number and expiration date, or a money order. Please do not send cash.
- Tag product with your name, street address, phone number and your assigned Repair Authorization Number.
- Include a brief written description of the problem.
- Return product freight prepaid to Humminbird, using an insured carrier with delivery confirmation.

 **WARNING!** This device should not be used as a navigational aid to prevent collision, grounding, boat damage, or personal injury. When the boat is moving, water depth may change too quickly to allow time for you to react. Always operate the boat at very slow speeds if you suspect shallow water or submerged objects.

 **WARNING!** Disassembly and repair of this electronic unit should only be performed by authorized service personnel. Any modification of the serial number or attempt to repair the original equipment or accessories by unauthorized individuals will void the warranty.

CONTACT HUMMINBIRD

Web site humminbird.com

E-mail service@humminbird.com

Telephone 1-800-633-1468

Direct Shipping Humminbird
Service Department
678 Humminbird Lane
Eufaula, AL 36027 USA

ENVIRONMENTAL COMPLIANCE STATEMENT: It is the intention of Johnson Outdoors Marine Electronics, Inc. to be a responsible corporate citizen, operating in compliance with known and applicable environmental regulations, and a good neighbor in the communities where we make or sell our products.

WEEE DIRECTIVE: EU Directive 2002/96/EC "Waste of Electrical and Electronic Equipment Directive [WEEE]" impacts most distributors, sellers, and manufacturers of consumer electronics in the European Union. The WEEE Directive requires the producer of consumer electronics to take responsibility for the management of waste from their products to achieve environmentally responsible disposal during the product life cycle.

WEEE compliance may not be required in your location for electrical & electronic equipment [EEE], nor may it be required for EEE designed and intended as fixed or temporary installation in transportation vehicles such as automobiles, aircraft, and boats. In some European Union member states, these vehicles are considered outside of the scope of the Directive, and EEE for those applications can be considered excluded from the WEEE Directive requirement.



This symbol [WEEE wheelie bin] on product indicates the product must not be disposed of with other household refuse. It must be disposed of and collected for recycling and recovery of waste EEE. Johnson Outdoors Marine Electronics, Inc. will mark all EEE products in accordance with the WEEE Directive. It is our goal to comply in the collection, treatment, recovery, and environmentally sound disposal of those products; however, these requirements do vary within European Union member states. For more information about where you should dispose of your waste equipment for recycling and recovery and/or your European Union member state requirements, please contact your dealer or distributor from which your product was purchased.