



The 47KMFC fixed mounting system is designed to mount to flat surface applications. The four by 2.5" (64mm) bolt pattern accepts multiple styles of fasteners providing ease of fitment to existing vehicles while also speeding assembly. The KMFC mount accepts either 5/16" or 8mm bolts and nuts. Three bolting configurations are designed into the mount providing the customer with options to best fit their application:

- Bolt-thru-mounting
- Bolt-to-mounting
- Stud mounting

This document addresses these configurations to provide insight into the capability of the KMFC mounting system.

## MOUNTING YOUR NEW ENCLOSURE

The use of flat washers is suggested between the mounting surface and tightening fastener. Loctite Threadlocker 271 (red) is not included but required for installation. The following parts identified are included and required for mounting your new enclosure.

1. Electrical Connector
2. 5/16"-18UNC hex nuts
3. 1½" long 5/16"-18UNC hex head bolts
4. 7/8" long 5/16"-18UNC socket head bolts
5. Vehicle Mount
6. Speaker Enclosure

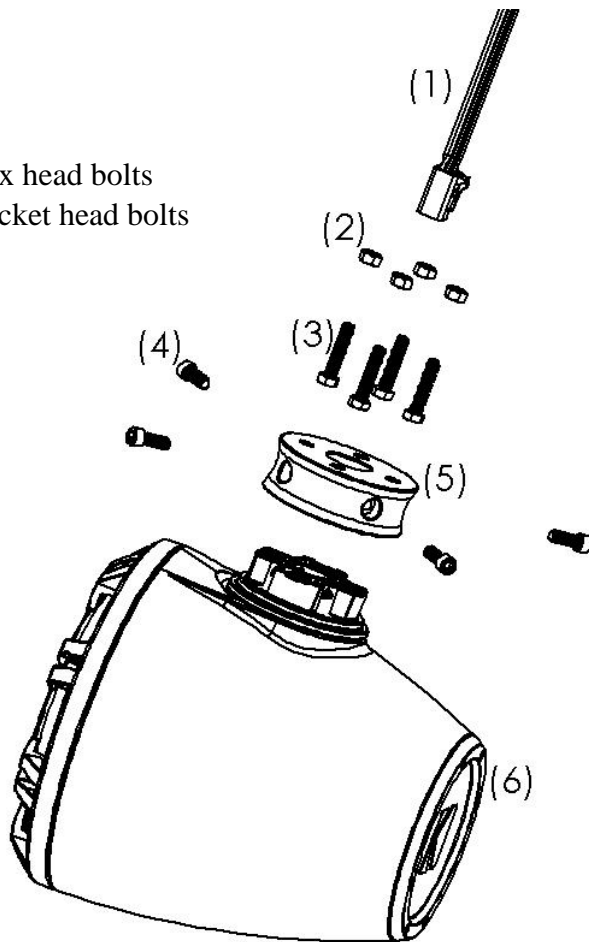



## SPLICING THE ELECTRICAL CONNECTORS

A pre-pinned waterproof electrical connector is provided with your enclosure. Splice the electrical connector to your vehicle's audio harness using marine grade waterproof butt connectors or another method of marine grade electrical wire splicing. See the wiring schematic below and splice accordingly.

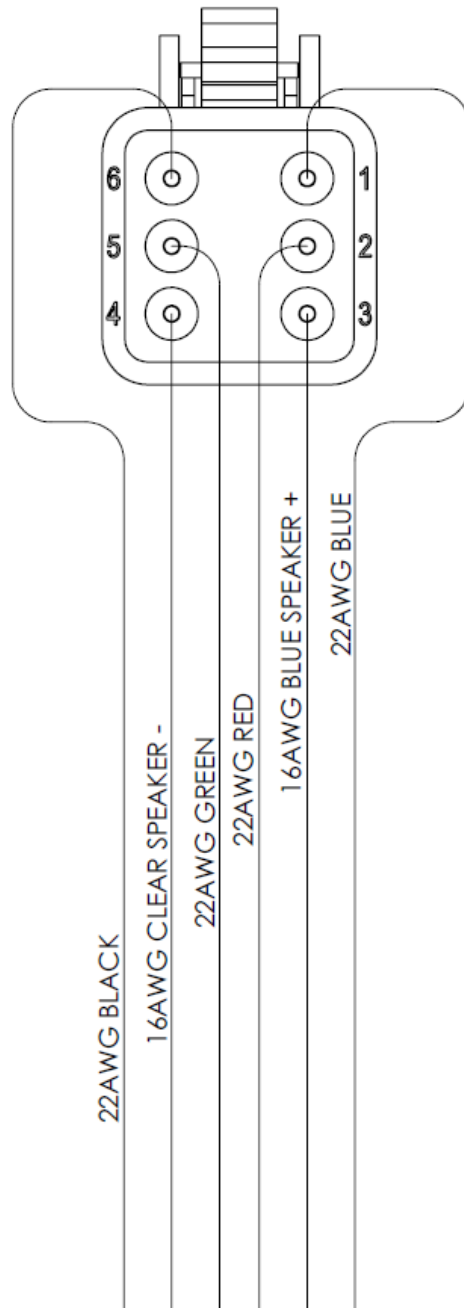



## BOLT-THRU-MOUNTING

Bolt-thru-mounting of the KMFC mounting system requires use of socket head bolts (socket head bolts for bolt-thru-mounting are not included). Thru mounting allows for the mount to be secured to a surface that has previously been tapped with threads. Nuts may also be use in place of tapped threads.

1. Apply Loctite Threadlocker 271 (red) to the threads of the desired length 5/16"-18UNC socket head bolts.

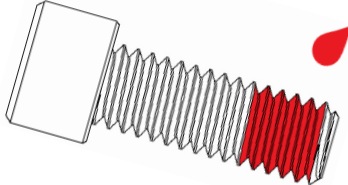

2. Locate the vehicle side mounting bracket where it is to be mounted in on the vehicle and secure it using four socket head bolts.

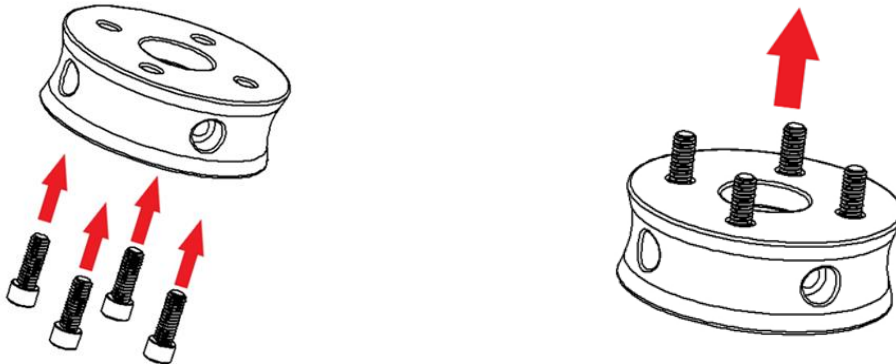

3. Torque fasteners to 10 ft-lbs.

10 ft-lbs

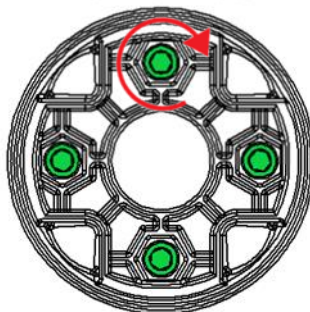



4. Plug the electrical connector into the speaker enclosure.

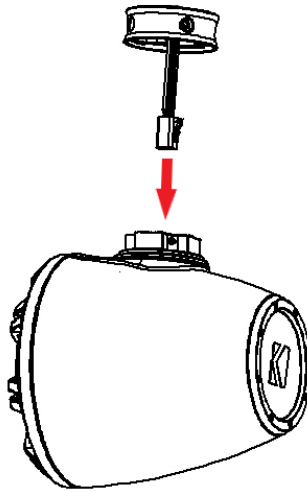

5. Apply the supplied anti-seize to the 7/8" long 5/16"-18UNC socket head bolts included with the enclosures.
6. Orient enclosure into the mount as desired and secure using the four supplied 7/8" long 5/16"-18UNC socket head bolts.

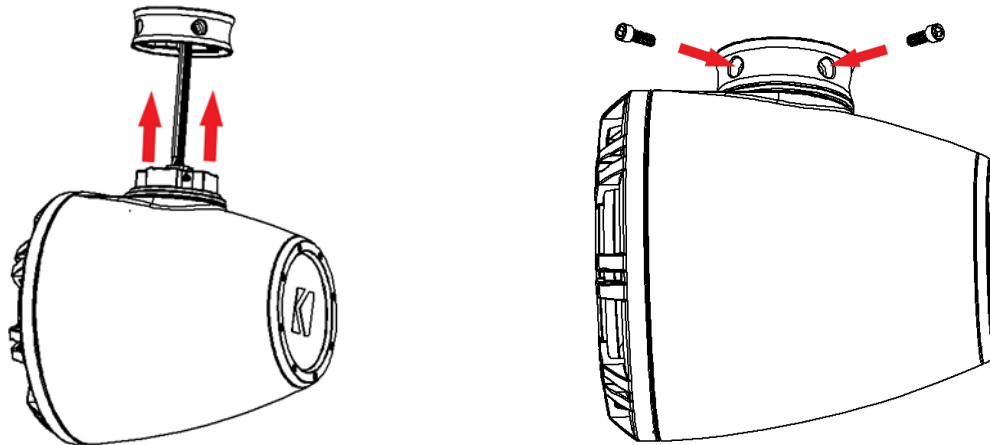

7. Torque 7/8" long 5/16"-18UNC socket head bolts to 10 ft-lbs.

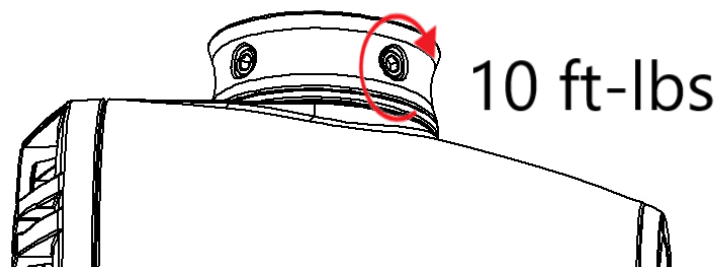



## BOLT-TO-MOUNTING

Bolt-to-mounting allows for the mounting system and speaker to be pre-assembled and then bolted to a surface. Unlike bolt-thru-mounting, nuts are secured within the mount and the mount is assembled onto the enclosure. The bolts are routed through the mounting surface and then the bolts thread into the mount.

1. Place the supplied four 5/16"-18UNC hex nuts into the mount.

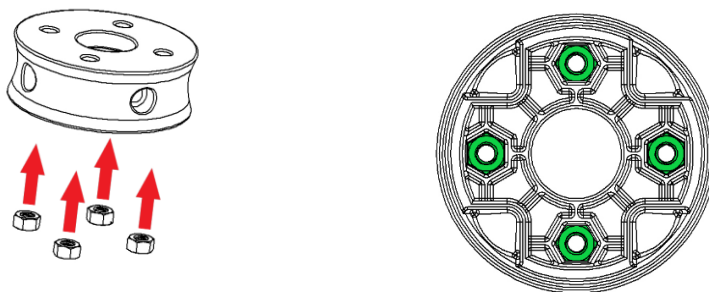

2. Apply the supplied anti-seize to the 7/8" long 5/16"-18UNC socket head bolts included with the enclosures.
3. Place the mount, with 5/16"-18UNC hex nuts in it, onto the enclosure and secure using the four supplied 7/8" long 5/16"-18UNC socket head bolts.

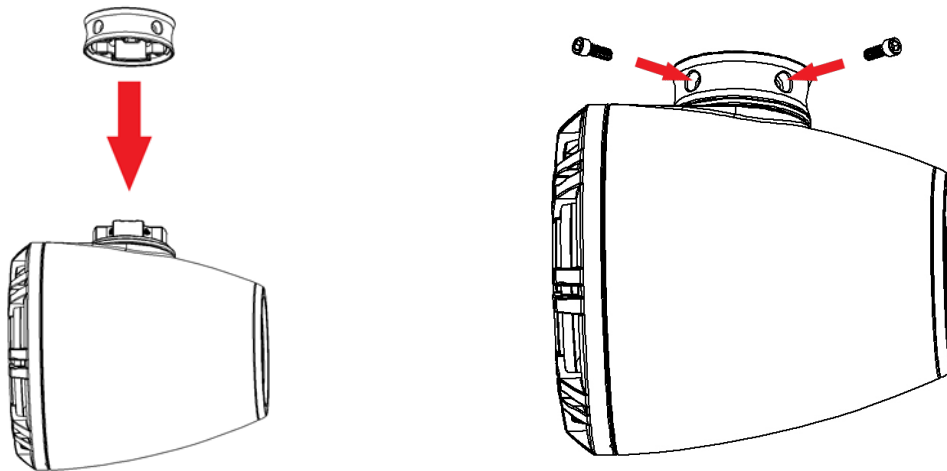

4. Torque 7/8" long 5/16"-18UNC socket head bolts to 10 ft-lbs.

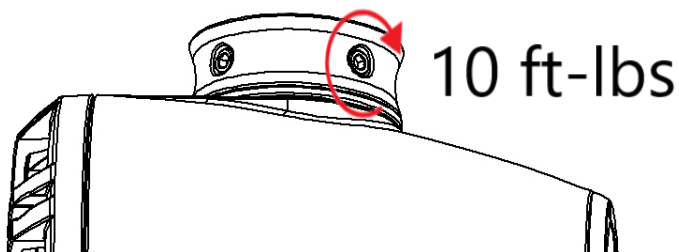



5. Apply Loctite Threadlocker 271 (red) to the threads of the supplied 1½” long 5/16”-18UNC hex head bolts.

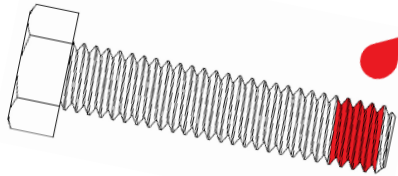

6. Plug the electrical connector into the speaker enclosure.

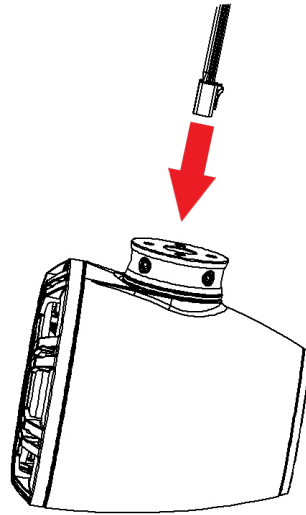

7. Hold enclosure up to the desired surface and thread 1½” long 5/16”-18UNC hex head bolts through surface and into 5/16”-18UNC hex nuts. Torque bolts to 10 ft-lbs.

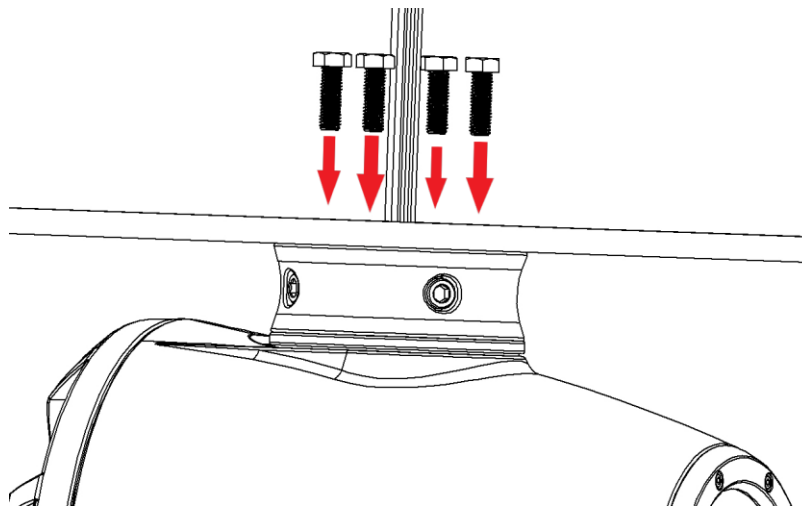



## STUD MOUNTING

Similar to Bolt-to-Mounting, Stud Mounting allows for the mounting system and speaker to be pre-assembled and then bolted to a surface. The mounting bolts are retained inside the mount creating studs to secure the enclosure to the desired surface. Nuts are threaded onto the studs securing the enclosure in place.

1. Place the supplied four 1½” long 5/16”-18UNC hex head bolts through the mount.

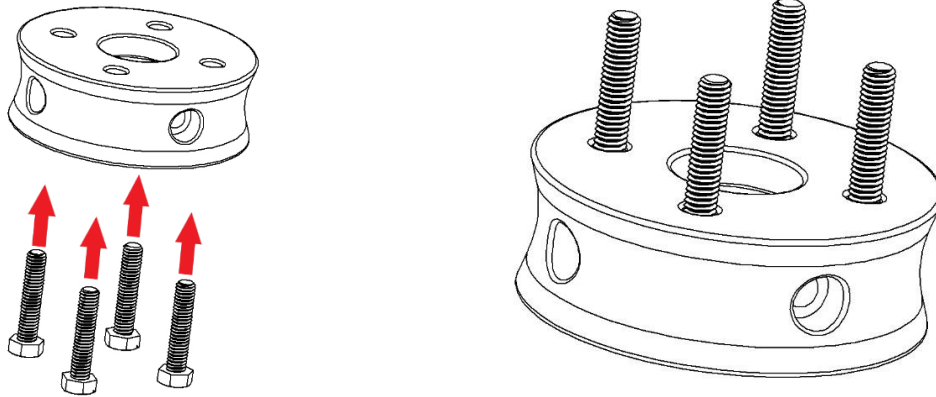

2. Apply the supplied anti-seize to the 7/8” long 5/16”-18UNC socket head bolts included with the enclosures.
3. Place the mount with nuts in it onto the enclosure and secure using the four supplied 7/8” long 5/16”-18UNC socket head bolts.

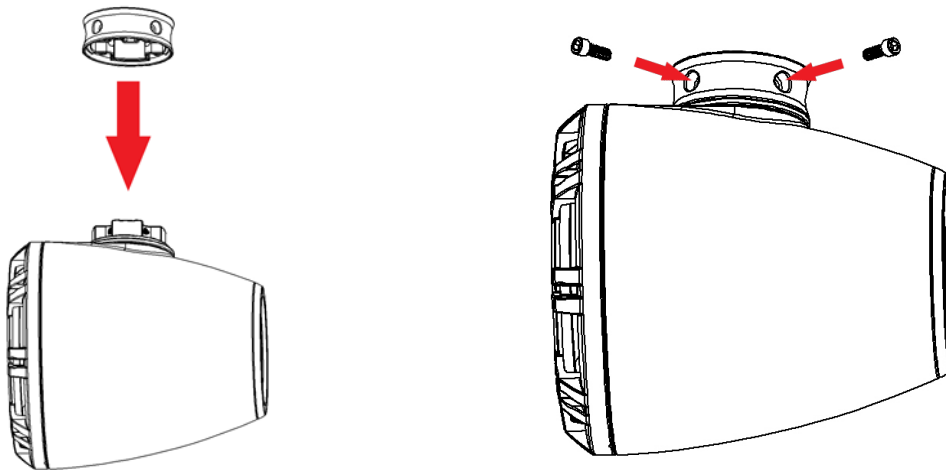



4. Torque 7/8" long 5/16"-18UNC socket head bolts to 10 ft-lbs.

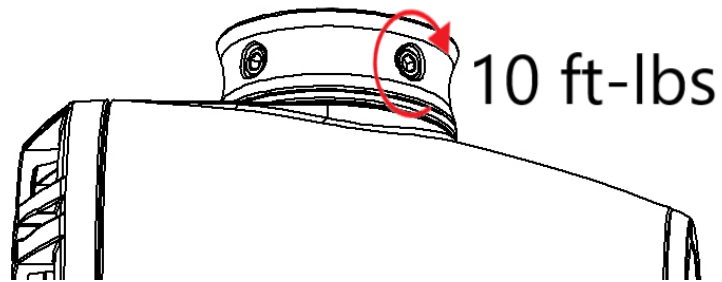

5. Apply Loctite Threadlocker 271 (red) to the threads of the 1 1/2" long 5/16"-18UNC hex head bolts.

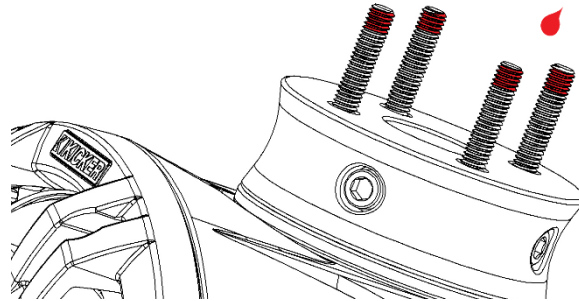

6. Plug the electrical connector into the enclosure.

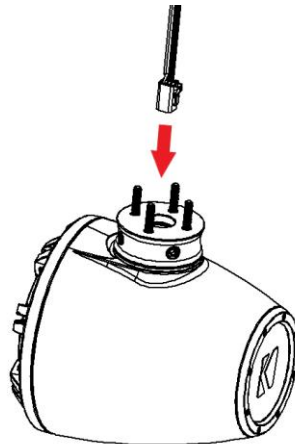





7. Place enclosure on desired surface and secure using the 5/16"-18UNC hex nuts.

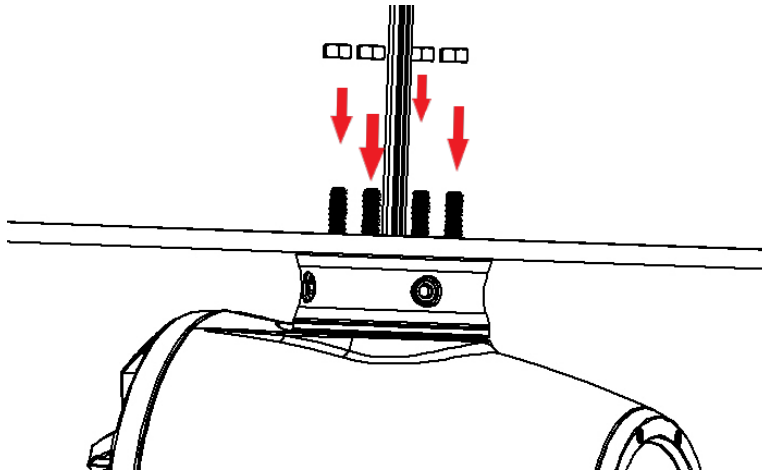

8. Torque the four 5/16"-18UNC hex nuts to 10 ft-lbs.

